

FAN EQUIPMENT OPERATION MANUAL

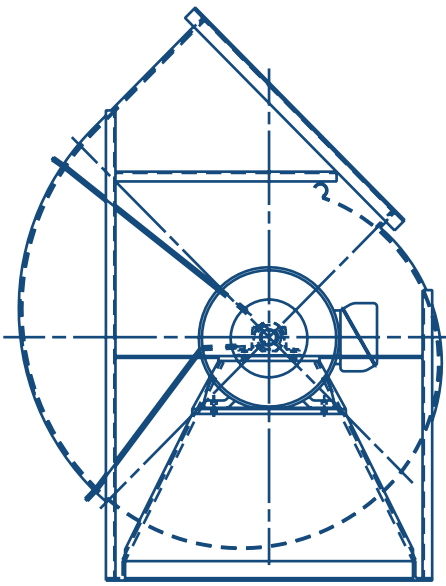

Fan Serial No. _____

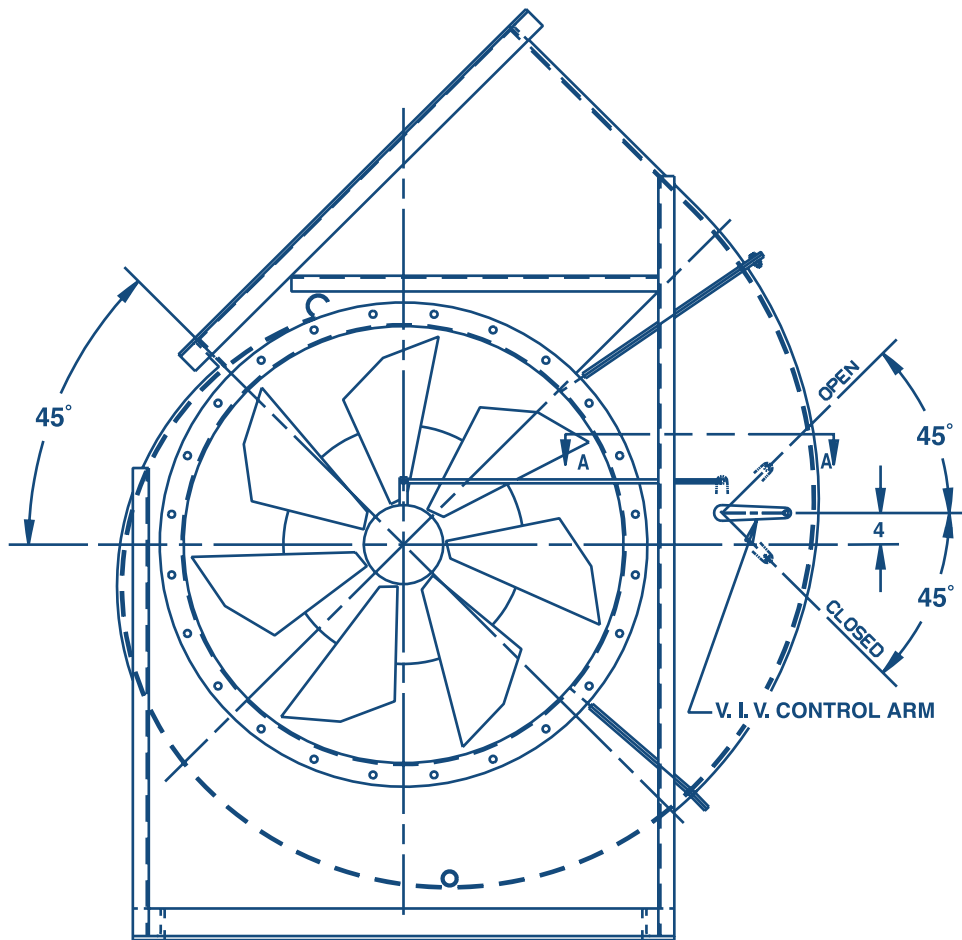

**NORTHERN
BLOWER®**

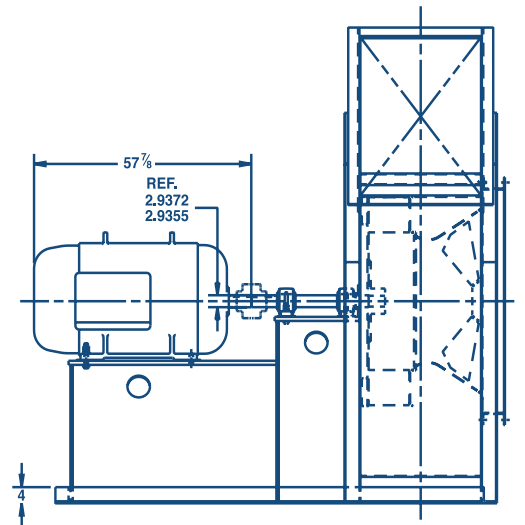



MEMBER

Air Movement and Control Association
30 West University Drive
Arlington Heights, Illinois 60004

TABLE OF CONTENTS

STANDARD TERMS AND CONDITIONS and WARRANTY.....	4
Standard Terms and Conditions	4
Warranty	5
OPERATION MANUAL - FAN EQUIPMENT	6
SAFETY PRECAUTIONS.....	6
INSTALLATION, OPERATION & MAINTENANCE OF NORTHERN BLOWER FAN EQUIPMENT	7
Introduction.....	7
Shipment & Receiving	7
Handling	7
Storage.....	8
Installation of Fan Equipment	8
V-Belt Drive Installation	9
Operation of Fan Equipment	10
Maintenance of Fan Equipment.....	11
FAN TROUBLE-SHOOTING CHART	14
OTHER INSTALLATION INSTRUCTIONS AND LITERATURE.....	15

Published by
NORTHERN BLOWER INC.
Telephone 204-222-4216
Telefacsimile 204-222-7601
901 Regent Avenue West
WINNIPEG, MANITOBA
CANADA
R2C 2Z8

1990

NORTHERN BLOWER INC.

STANDARD TERMS AND CONDITIONS and WARRANTY

STANDARD TERMS AND CONDITIONS

ACCEPTANCE AND PRICES: Prices quoted for products manufactured by the Northern Blower Inc. (herein "Seller") are subject to acceptance by the Purchaser no later than thirty (30) days from the date of the Seller's Quotation-Proposal (herein "Quotation-Proposal"). Until acceptance by the Purchaser (sometimes herein called the "Customer") as aforesaid, the Seller reserves the right in its sole and absolute discretion to withdraw any Quotation-Proposal for any reason whatsoever. In addition, the Seller reserves the right in its sole and absolute discretion, to withdraw at any time and whether before or after acceptance by the Customer, any Quotation-Proposal previously made by it, if in its opinion, such Quotation-Proposal was based upon incorrect, incomplete, or misleading information relayed to it by the Customer or any person, firm or corporation acting on behalf of the Customer. In any such event, any such Quotation-Proposal shall be null and void, ab initio, and the Seller shall have no responsibility therefore or for the withdrawal thereof.

Prices quoted for items which are not manufactured by the Seller such as motors and drives, et cetera are subject to change at any time the cost of such items charged to the Seller changes.

Prices on orders for products manufactured by the Seller are firm provided approval and release for production and shipment is received from the Customer within sixty (60) days of the date of Seller's receipt of the Customer's order and the products are shipped within six (6) months of the date of the Seller's receipt of the Customer's order. When such approval and release for production and shipment is received after sixty (60) days of the date of Seller's receipt of the Customer's order or products are shipped after six (6) months of the date of Seller's receipt of the Customer's order, such prices are subject to adjustment to the Seller's prices in effect on the date approval and release from the Customer is received by the Seller, or at time of shipment, as the case may be.

Orders for non-stock equipment released for production and scheduled by the Seller cannot be rescheduled by the Customer unless it is done at least eight (8) weeks before the Seller scheduled shipping date. If production is started the Customer must accept delivery when the order is ready for shipment.

Acceptance by the Customer of any physical goods (herein "Equipment"), drawings, or services from the Seller shall constitute acceptance the Seller's Standard Terms and Conditions. No term and / or condition appearing in the Purchaser's order that is in variance with or contrary to the Seller's Standard Terms and Conditions shall be binding on the Seller unless specifically agreed to in writing.

TERMS OF PAYMENT: Terms of payment are net thirty (30) days subject to the prior approval of the Seller's Credit Department. Payment for equipment or services exceeding \$200,000.00 Canadian Funds, or foreign monetary equivalent, may require pre-payment through installments subject to the prior approval of the Seller's Credit Department. Notwithstanding such approval, if, at any time, in the sole judgment of the Seller, the Customer's financial condition does not merit the approved terms, the Seller may require partial or full payment prior to the commencement or continuation of manufacture of equipment or provision of service. Overdue accounts will bear interest at the rate then available to the Seller from its banker for line-of-credit facilities, plus two (2) additional percentage points.

CANCELLATIONS: Accepted orders cancelled by the Customer are subject to cancellation charges for all expenses incurred, profits lost, and commitments made by the Seller. The cancellation charges on completed items will be one hundred (100%) percent of the selling price. The aforementioned cancellation charges shall not in any way whatsoever limit Seller's other remedies it may have at law including, without limiting the generality of the foregoing, the ability of the Seller to claim and recover any amounts or damages to which the Seller would otherwise be entitled by reason of accepted orders cancelled by the Customer.

TITLE & RISK OF LOSS & FREIGHT CLAIMS: Unless otherwise expressly agreed in writing, delivery of the product is made FCA (per

Incoterms 2000) the Seller's Winnipeg, Manitoba, Canada plant. The liability and responsibility of the Seller for the product ceases upon delivery of the product in good order to the carrier and title and risk of loss shall transfer to Customer upon such delivery. All claims for damage and shortage in transit are the Customer's responsibility and the Customer must file the claim against the carrier. Claims for factory shortage will not be recognized unless such alleged shortage is reported to the Seller in writing within ten (10) days after receipt of the product.

TAXES: The amount of any present or future taxes shall be added to the price contained herein and shall be paid by the Customer in the same manner and with the same effect as if originally added thereto.

DELAYS: The Seller will use its best efforts to provide Equipment or services by the estimated date, but the Seller shall not be liable in damages or otherwise for failure to do so, regardless of the cause. Not to limit the generality of the foregoing, the Seller shall not be liable to the Customer or to any third party for any delays caused by Acts of God, riots, strikes, lockouts, weather, fire, floods, lack of transportation, accidents, the failure of the Seller's suppliers to meet their contractual obligations, breakdowns, or any other contingency beyond Seller's reasonable control and receipt of the product by the Customer shall constitute a waiver of all claims for loss or damage due to delay. Except as specifically provided herein, the Seller will not be liable, in any circumstances, for any loss or damage of whatever nature or kind (including, without limiting the generality of the foregoing, direct, indirect, incidental or consequential loss or damage or damage resulting from business interruption).

Shipments held beyond the scheduled date as a result of a request or action of the Customer will be billed immediately to the Customer as well as expenses related to the delay, including, but not limited to, charges for the storage of the Equipment, and the Customer shall assume title and risk of loss thereof.

PRODUCT CHANGES: The Seller reserves the right to change or modify the product in the interest of continuous product improvement without liability, to the Customer.

RETURNED GOODS: Goods may not be returned except by the written permission of the President, General Manager or General Sales Manager of the Seller and when so returned will be subject to a handling charge and transportation costs.

MODIFICATION and IMMEDIATE EFFECT: These Standard Terms and Conditions take effect immediately on the date of publication and replace and supersede any Standard Terms and Conditions published prior hereto, notwithstanding that the Purchaser may have been provided with the same by Seller or its representatives or agents in error or through inadvertence. These Standard Terms and Conditions may not be modified except by written agreement signed by the General Manager or Sales Manager of the Seller. The failure of the Seller to object to provisions contained in the Customer's purchase orders or other communications shall not be deemed waiver of the Standard Terms and Conditions hereof or acceptance of such provisions. No other terms and conditions other than the Standard Terms and Conditions contained herein and those terms and conditions with respect to the description of product, quantity and price contained in the Quotation-Proposal shall be binding upon the Seller unless made in writing and signed by the General Manager or General Sales Manager of the Seller. Without restricting the generality of the foregoing, agents and sales representatives of the Seller do not have authority to modify these Standard Terms and Conditions.

TIME of the ESSENCE: Time is of the essence in these Standard Terms and Conditions.

PROPER LAW OF CONTRACT: These Standard Terms and Conditions and any agreement or contract of which they form an integral part shall be interpreted in accordance with the laws of the Province of Manitoba in the Dominion of Canada. All proceedings related to the interpretation or enforcement of any agreement or contract shall take place exclusively in the Courts of Manitoba, to which parties hereto and irrevocably attorn.

WARRANTY

Northern Blower Inc. (the "Seller") warrants products of its manufacture (the "product", "equipment" or "fan") to be free of defects in material and workmanship if properly installed, and cared for, and operated under normal conditions, and with competent supervision, all in accordance with the Seller's Operation Manual. If any questions exist as to whether the proposed operation of the Seller's equipment is within "normal conditions" for such equipment, details of such proposed operation should be provided to the Seller at its Winnipeg factory. The Seller will review the proposed operation of the equipment (at a fee) and advise if the proposed operation is acceptable.

- (1) The Seller's obligation under this warranty is limited to the repair or replacement, at its option at its Winnipeg factory, of any defective part or parts which shall within one (1) year after shipment thereof to the original Customer (the "Customer"), be returned to its Winnipeg factory with transportation charges prepaid by the Customer and upon such repair or replacement the Seller shall have fulfilled all its obligations to the Customer. The Seller will not be liable, in any circumstances, for costs or expenses incurred by the Customer or any person claiming through the Customer in the removal or replacement of equipment alleged to be defective. Except as specifically provided herein, the Seller will not be liable, in any circumstances, for any loss or damage of whatever nature or kind (including, without limiting the generality of the foregoing, direct, indirect, incidental or consequential loss or damage or damage resulting from business interruption) should the equipment be so defective as to preclude the remedy of warranted defects by repair or replacement. In such event, the Customer's sole and exclusive remedy shall be the refund of the purchase price paid by the Customer for all the defective equipment.
- (2) The Seller shall not be liable for the repair or replacement of any such defective part or parts, or for loss, damage, or any expense of repairs when any adjustment, alteration or repair shall have been made or attempted outside of its factory, except if such adjustment, alteration or repair outside its factory is made or attempted after the Seller's written consent is first obtained.
- (3) The Seller shall not be liable for any corrosion or fouling caused by any foreign substance deposited in or on the equipment.
- (4) Because the Seller is unaware of any forms of construction, materials, alloys or coatings which will successfully resist all abrasion, erosion, corrosion, or deterioration from excessive heat, the Seller's warranty does not apply when any of its products or equipment are subjected to conditions which cause such abrasion, erosion, corrosion or deterioration from excessive heat or any damages similar or related thereto.
- (5) The performance of the Seller's fan equipment outside of the laboratory may vary widely and differ from the performance specifications contained in its sales literature. Therefore, the Seller cannot and does not guarantee or warrant the performance of its fan equipment at the Customer's location.
- (6) ALL WARRANTIES OF THE SELLER, EXPRESS OR IMPLIED, WITH RESPECT TO MOTORS, SWITCHES, CONTROLS OR OTHER ACCESSORIES NOT MANUFACTURED BY THE SELLER, INCLUDING WARRANTIES OF MERCHANTABILITY, QUALITY OR FITNESS FOR ANY PARTICULAR PURPOSE, ARE HEREBY EXCLUDED.
- (7) The Seller shall have no liability under the terms of this Warranty or otherwise where the Customer undertakes the responsibility of mounting the fan wheel directly to the motor or turbine shafts without the Seller having inspected and tested the assembled unit (at a fee) before the fan is operated in any fashion. If the Seller does not inspect and test the assembled unit within ten (10) days of being requested to do so by the Customer and receipt of payment of the aforementioned fee, the Seller shall be deemed to have waived its requirement to inspect and test the assembled unit.
- (8) The Seller shall have no liability under the terms of this warranty or otherwise until the Customer has made full payment to the Seller for the product or equipment to which this warranty is to apply.
- (9) NOWARRANTIES WHATSOEVER, EXPRESS OR IMPLIED, INCLUDING WARRANTIES OF MERCHANTABILITY, QUALITY OR FITNESS FOR ANY PARTICULAR PURPOSE, ARE MADE BY THE SELLER EXCEPT AS EXPRESSLY PROVIDED HEREIN.
- (10) The terms of this warranty may not be modified except by written agreement signed by the General Manager or Sales Manager of the Seller. The Seller's failure to object to provisions contained in the Customer's purchase orders or other communications shall not be deemed waiver of the terms and conditions hereof nor acceptance of such provisions. No representations or warranties other than those contained herein shall be binding upon the Seller unless made in writing and signed by the General Manager or General Sales Manager of the Seller. Without restricting the generality of the foregoing, agents and sales representatives of the Seller do not have authority to modify the terms of this Warranty or make representations or warranties other than those contained herein.

NORTHERN BLOWER INC. OPERATION MANUAL - FAN EQUIPMENT

SAFETY PRECAUTIONS

FAN EQUIPMENT CAN BECOME A SOURCE OF INJURY AND DEATH IF NOT PROPERLY INSTALLED, OPERATED OR MAINTAINED. Do not exceed the maximum operating temperature or speed limits for which the fan equipment was designed. Limits for some lines of fan equipment are given in Northern Blower Inc. ("Northern") catalogues. Limits for non-catalogued lines of fan equipment should be obtained in writing from the Northern Winnipeg factory and not otherwise. Do not rely on limits obtained in any other manner.

The user should make all personnel who operate or maintain the fan equipment aware of all possible hazards.

THE RESPONSIBILITY FOR PROVIDING SAFETY ACCESSORIES FOR FAN EQUIPMENT SUPPLIED BY NORTHERN IS THAT OF THE USER OF THE FAN EQUIPMENT. Northern sells its fan equipment with or without safety accessories, and accordingly, it can supply standard safety accessories upon receipt of an order. Ensure that all necessary safety accessories have been installed before operation of the fan equipment.

The warning notice set out below should be affixed upon the fan equipment:

NORTHERN BLOWER INC.

WARNING

This fan has rotating parts and may be hot. Keep body, hands and foreign objects away from inlet and outlet. Do not touch fan or motor during operation.

Operate, install and maintain only in strict accordance with safety practices and instructions in manufacturer's Operation Manual. Do not exceed the maximum operating temperature, speed, or vibration level identified in the manufacturer's catalogues and Operation Manual. Untrained personnel should never operate, install, adjust or maintain fan or motor.

ADDITIONAL SAFETY ACCESSORIES FOR THE FAN EQUIPMENT ARE AVAILABLE FROM THE MANUFACTURER. THE RESPONSIBILITY FOR PROVIDING SUCH ADDITIONAL SAFETY ACCESSORIES IS THAT OF THE USER OF THE FAN EQUIPMENT. CONSULT THE MANUFACTURER'S OPERATION MANUAL FOR GUIDANCE.

Before starting maintenance work, lock disconnect switch in the off position, de-energize and disconnect all power sources to the motor and to accessory devices and secure fan impeller. Cleanout doors must be secure during operation. Unsecured cleanout doors may shoot open during operation because of pressure build up inside the fan.

Do not start-up when fan impeller is rotating backwards.

FAILURE TO FOLLOW MANUFACTURER'S INSTRUCTIONS AS TO OPERATION, INSTALLATION, ADJUSTMENT, MAINTENANCE, SAFETY EQUIPMENT OR APPROPRIATE OPERATING CONDITIONS COULD RESULT IN DAMAGE TO THIS EQUIPMENT, DAMAGE TO OTHER EQUIPMENT, PERSONAL INJURY OR DEATH.

Should the warning notice not be affixed to the fan equipment purchased, Northern will supply such a warning notice upon request made to its head office.

The user of the fan equipment, in making its determination as to the appropriate safety accessories to be installed and any additional warning notices to be affixed upon the fan equipment, should consider (1) the location of the installation of the fan equipment, (2) the accessibility of employees

and other persons to the fan equipment, (3) any adjacent equipment, (4) applicable building codes, and (5) applicable health and safety legislation.

Users and installers of the fan equipment should read "RECOMMENDED SAFETY PRACTICES FOR AIR MOVING DEVICES" which is published by the Air Movement and Control Association, 30 West University Drive, Arlington Heights, Illinois, 60004.

INSTALLATION, OPERATION & MAINTENANCE OF NORTHERN FAN EQUIPMENT

INTRODUCTION

The purpose of this section is to aid in the proper installation, operation, and maintenance of Northern fan equipment. These instructions are intended to supplement good general practices and are not intended to cover detailed instruction procedures.

The receipt, handling, installation, operation and maintenance of Northern fan equipment is the responsibility of the user. It is important that the installation and start-up of the fan equipment be supervised or inspected by personnel experienced in such work and equipment. Trained personnel are available from Northern, and arrangements for such supervision and inspection (at a fee) should be made through your local Northern representative or at Northern's head office. Failure to arrange for such supervision or inspection may affect or void the Northern Warranty (please refer to paragraph 7 of Northern's Warranty).

SHIPMENT & RECEIVING

Northern has thoroughly inspected the fan equipment at its factory and has prepared the fan equipment for shipment in accordance with the uniform freight classification followed by all carriers. The fan equipment should be in perfect condition when received, unless damaged in transit. Upon acceptance by the carrier, as evidenced by a signed bill of lading, the carrier accepts responsibility for all shortages or damage, whether concealed or evident. Claims covering shortages or damage must be made to the carrier by the purchaser. Any shortages or damage should be noted by the user on the delivery receipt.

The fan equipment may contain components manufactured by manufacturers other than Northern. Such other manufacturers may have furnished instructions and/or other literature concerning their component. A list of such instructions and/or other literature is forwarded with the fan equipment (see page 15 of this manual). If any of the items on the list are missing, please contact your Northern representative, Northern at its head office or contact the component's manufacturer directly.

HANDLING

The fan equipment should be handled with care. Some fans are provided with lifting lugs or holes for easy handling. Others must be handled using nylon straps or well-padded chains and cables which protect the fan's coating and housing. Spreader bars should be used when lifting large parts.

Axial fans should be lifted by using straps around the fan housing only. **DO NOT LIFT AXIAL FANS BY THE MOTOR, MOTOR BASE, IMPELLER OR FLANGES.**

Centrifugal fans are best lifted using straps attached

to structural base members of the fan. **DO NOT LIFT CENTRIFUGAL FANS BY THE FAN SHAFT, IMPELLER, FLANGES OR INLET SUPPORTS.**

Roof ventilators should be lifted by using straps attached to lifting lugs or base only. Spreader bars should also be used to avoid damage to the butterfly damper assembly or the weatherhood. **DO NOT LIFT ROOF VENTILATORS BY THE BUTTERFLY DAMPER ASSEMBLY OR WEATHERHOOD.**

Centrifugal rotor assemblies (i.e. impeller and shaft assemblies) have been designed to be supported by the shaft, and should be lifted by slings around the shaft as close as possible to the hub on each side of the impeller (wheel). Slings should not press against the side plates of the wheel as this may damage and distort the wheel. A spreader bar should be used when lifting the rotor assembly (Figure 1). The wheel should never rest on the side plates or blades, nor should the rotor assembly be lifted by any components of the fan wheel. To do so may damage the rotor assembly and destroy the dynamic balance that is necessary for low vibration operation. If this balance is destroyed, rebalancing of the rotor assembly will be necessary. If the wheel and shaft have not been assembled, the fan wheel may be lifted by a timber or wrapped bar of sufficient strength passed through the hub. The finished bore of the hub and the bearing surfaces of the shaft must also be protected from damage.

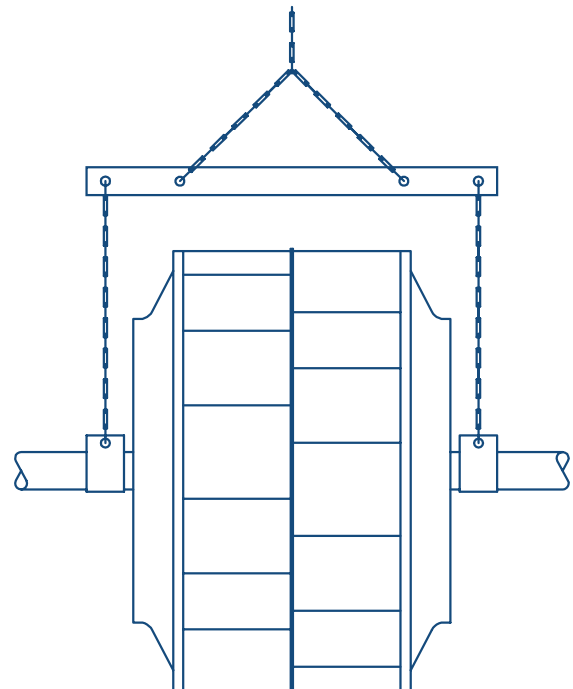

Fig. 1 Correct use of spreader bar when lifting centrifugal rotor assembly.

STORAGE

If fan equipment is not installed immediately, fans should be protected so as to remain dry at all times.

(1) If temporary storage is necessary:

Store in a dry area which is free of any vibration, and protect from extremes and rapid changes in humidity and temperature.

- (A) Temperatures: between 50°F (10°C) and 120°F (49°C).
- (B) Maximum relative humidity: 60%.
- (C) Shock or vibration: 2 mils displacement maximum to prevent bearings from brinelling. Exceeding this limit will require vibration dampening material under the fan equipment.

(2) If extended storage is necessary:

Motor bearings and fan bearings are to be lubricated at the time of placement into extended storage. Motor shafts and fan shafts are to be manually rotated every month and additional lubricant added, purging some of the lubricant in the bearing cavity every six (6) months. LUBRICANT IN THE BEARINGS IS TO BE PURGED AT THE TIME OF REMOVAL FROM STORAGE, ENSURING THAT AN AMPLE SUPPLY OF FRESH LUBRICANT IS IN EACH LUBRICANT CAVITY. LUBRICANT USED MUST BE COMPATIBLE WITH THE LUBRICANT ALREADY IN THE MOTOR AND FAN BEARINGS.

Electric motors in storage may absorb moisture in their windings which may result in a significant loss of insulation resistance. When removed from storage the insulation resistance of all motors should be checked in accordance with the motor manufacturer's instructions or in accordance with IEEE standard 43-1974 "IEEE Recommended Practice for Testing Insulation Resistance of Rotating Machinery". Motors with insufficient insulation resistance must be cleaned and dried in accordance with motor manufacturer's instructions or IEEE standard 43-1974 to return the insulation resistance to acceptable levels. THE APPLICATION OF POWER TO A MOTOR WITH INSUFFICIENT INSULATION RESISTANCE MAY RESULT IN DAMAGE TO THE MOTOR OR DAMAGE TO OTHER EQUIPMENT.

On v-belt drive fans, belts should be checked at the time of removal from storage for proper v-belt tension. Tighten belts if necessary (refer to the "V-BELT DRIVE INSTALLATION" section on page 9 of this manual).

When installing fan equipment after storage, follow the instructions contained in the "INSTALLATION OF FAN EQUIPMENT" and "OPERATION OF FAN EQUIPMENT" appearing at pages 8 and pages 10 of this manual respectively.

Storage records evidencing compliance with the above requirements should be maintained by the purchaser.

INSTALLATION OF FAN EQUIPMENT

- (1) Safe and smooth operation of the fan equipment requires a proper foundation that is level, rigid, and of sufficient structure and mass to support the equipment. IT IS ALWAYS IMPERATIVE TO CONSULT A QUALIFIED STRUCTURAL ENGINEER IN ORDER TO DESIGN A PROPER FOUNDATION.

A properly designed concrete base is the preferred foundation. The concrete base mass should be a minimum of four times that of the fan equipment when the plan view area of the concrete base is no more than twice the plan view area of the fan equipment.

Steel platforms or bases are good alternatives when properly designed. Steel platforms must be braced in all directions. Care must be taken to ensure that the natural frequency of all steel base components differs significantly from the rotating speed of the fan and the driver. FAILURE TO HEED THIS GOOD DESIGN PRACTICE MAY RESULT IN A RESONANT CONDITION AND CONSEQUENT LIFE THREATENING CATASTROPHIC STRUCTURAL FAILURE.

Fans mounted off ground level should be rigidly mounted to a structural platform and should be placed as near as possible to, or over, a solid wall or column (refer to paragraph one of this section).

Supports for suspended fans must be crossbraced to prevent side sway.

- (2) Fan equipment must be level prior to operation. Do not twist or distort fan equipment. Shim fan support points before tightening foundation bolts to help ensure distortion does not occur.
- (3) For roof mounted fans, place the fan curb panel on the roof curb. Level and then anchor the unit to the curb using lag screws, neoprene washers and flat washers. DO NOT MOUNT UNSUPPORTED STACKS ON THE FAN. STACKS MUST BE INDEPENDENTLY MOUNTED TO THE ROOF. Anchor independently mounted stacks with guy wires to prevent side sway.

- (4) Ducts must be independently supported, and must never be supported by the fan. Use flexible duct connections wherever possible. The independent mounting of stacks and ducts to the fan will ensure that the fan will not be twisted or deformed with the addition of external loads.
- (5) It is recommended that access doors be placed in ductwork just ahead of the fan inlet and just behind the fan outlet for ease of inspection and maintenance. **IN ORDER TO AVOID EQUIPMENT DAMAGE AND PERSONAL INJURY ACCESS DOORS IN A DUCT SYSTEM SHOULD BE SECURELY CLOSED AND SHOULD NEVER BE OPENED WITH THE FAN RUNNING.**
- (6) Lubricate fan bearings in strict accordance with bearing manufacturer's recommendations. Lubricate bearings upon receipt of fan. Do not over-lubricate. Bearings should be locked to the shaft. Ensure that locking mechanisms on bearings are in correct position and that locking mechanisms are fastened before operation of fan.
- (7) Flexible couplings must be installed and maintained in accordance with the coupling manufacturer's instructions. Refer to fan submittal drawings for details of drive arrangements and the general location of the coupling halves on the fan and motor shafts.

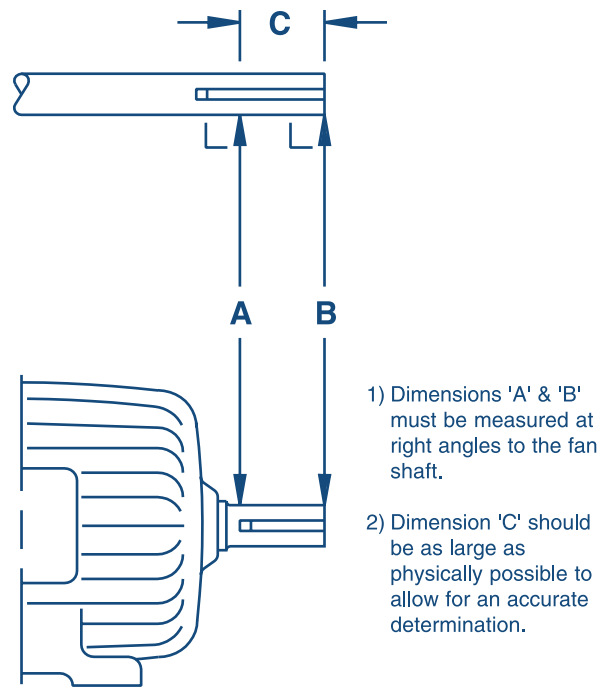

Fig. 2 Determination of parallel shafts.

V-BELT DRIVE INSTALLATION

V-belt drive systems are the most common type of belt systems used to drive fan equipment. Other types of belt systems are used ("cog", belts etc.) but are not discussed in this manual.

Proper alignment is essential to long fan bearing, driver bearing, v-belt and sheave life. Ensure that driver and fan shafts are parallel. The most common causes of misalignment are nonparallel shafts and improperly located sheaves. Where shafts are not parallel, v-belts on one side are drawn tighter and pull more than their share of the load. As a result, these v-belts wear out faster, requiring the entire set to be replaced before it has given maximum service. If the sheaves are misaligned, v-belts will enter and leave the grooves at an angle, causing excessive v-belt and sheave wear .

Shaft alignment can be checked by measuring the distance between the shafts at two or more locations as shown in Figure 2. If the distances are equal, the shafts are parallel.

Check the location of the sheaves on the shaft with a straight edge or a length of string. If the sheaves are properly aligned the string will touch them at the points indicated by the arrows in Figure 3. Rotating each sheave one-half (1/2) revolution will indicate if the sheave is misaligned or the shaft is bent. Correct any causes of misalignment.

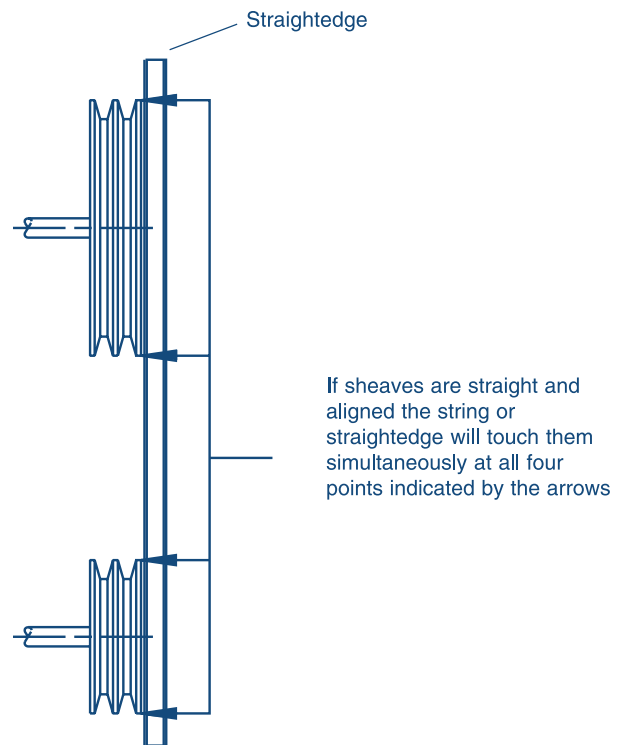

Fig. 3 Sheave alignment.

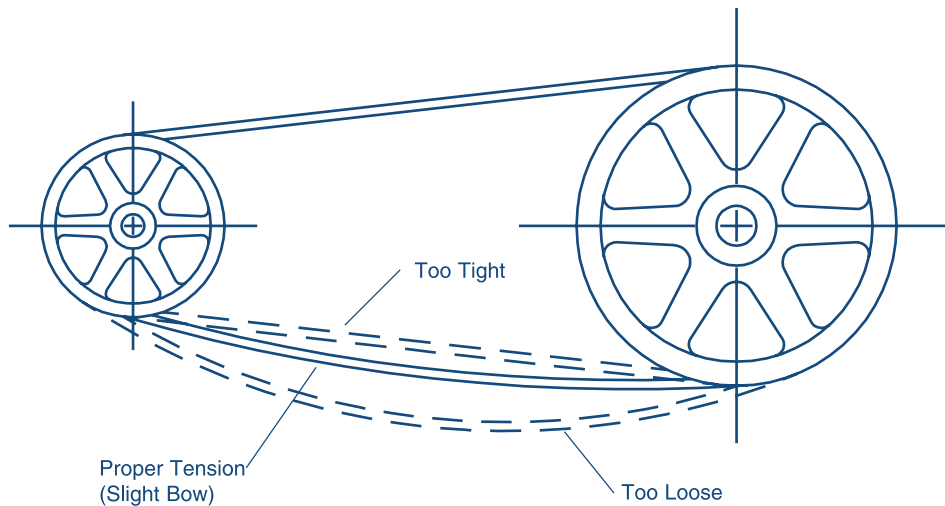

Fig. 4 Belt tension.

Always use matched v-belts and never mix new and used v-belts on a drive. Install v-belts correctly:

- (i) Shorten the center distance between the driven and driver sheave so the v-belts can be slipped into the sheave groove without damage. While the v-belts are still loose on the drive, rotate the drive until all the slack is on one side. Then increase the center distance until the v-belts are snug (Figure 4). NOTE: Never “roll” or “pry” the v-belts into the sheave grooves. This can damage the v-belt cords and lead to v-belt turnover, short life, or actual breakage. Moreover, it is both difficult and unsafe to install v-belts this way. Keep takeup rails, motorbase, or other means of center distance adjustment free of dirt, rust, and grit. Lubricate adjusting screws and slide rails as required.
- (ii) Operate the drive and fan a few minutes to seat the v-belts in the sheave grooves (operate the fan equipment only after following the procedure listed in the “Operation of Equipment” section of this manual). Observe the operation of the drive under its highest load condition (usually starting). A slight bowing of the slack side of the drive indicates proper tension. If the slack side remains taught during peak load, the drive is too tight. Excessive bowing or slippage indicates insufficient tension. If the v-belts squeal severely as the motor comes on or at some subsequent peak load, they are not tight enough to deliver the torque demanded by the fan. The fan should be stopped and the v-belts tightened.

- (iii) Check the tension on a new drive frequently during the first day of operation by observing the slack side span. After a few days of operation the belts will seat themselves in the sheave grooves and it may become necessary to readjust so that the drive again shows a slight bow in the slack side.

OPERATION OF FAN EQUIPMENT

- (1) Lock out all power sources.
- (2) Ensure that bearings are properly aligned and lubricated with special attention to the locking mechanisms, cleanliness, and possible corrosion. Bearings showing signs of corrosion must be replaced prior to operation of fan equipment.
- (3) Check set screws and keys (or taperlock hub if present) in fan impeller, and bolts on cooling wheel.
- (4) Check foundation bolts and other hardware for tightness.
- (5) Ensure that the fan housing, ducts, etc., are free of foreign objects.
- (6) Ensure that all access doors are secure.
- (7) Check the impeller to inlet cone and impeller to fan housing clearance to ensure that there is no interference. Turn the impeller by hand, ensuring that it rotates freely.
- (8) On belt drive fans, check sheave alignment and v-belt tension (refer to the section entitled “V-BELT DRIVE INSTALLATION” on page 9 of this manual).

- (9) If the fan is equipped with damper or variable inlet vane, close same to lessen starting load on motor. Ensure any dampers or variable inlet vanes furnished with the fan, or used in conjunction with the fan, do not stick or bind. If an automatic control mechanism is used to operate the damper or variable inlet vane, adjust the limits of travel of the automatic control mechanism in accordance with the control manufacturer's instructions to avoid putting force on the damper or variable inlet vane when it is fully opened or fully closed.
- (10) If the fan is driven by an electric motor, read instructions of motor and starter manufacturer. Ensure that the motor and starter are set up in compliance with the motor and starter manufacturers' instructions prior to any application of electric power. If the fan is powered by some other form of driver, read the manufacturer's instructions prior start-up.
- (11) If the fan is equipped with water cooled bearings turn on the water supply to the bearings prior to starting the fan. Consult the water cooled bearing manufacturer's instructions.
- (12) If the fan is to handle a "hot gas" (i.e. a gas with a temperature greater than 150°F [65°C]) it is imperative that the fan be subject to only a slow gradual rate of gas temperature change, not to exceed a rate of 15°F/minute (8°C/minute). When the fan is being put in operation the temperature of the gas must not rise at a rate greater than 15°F/minute (8°C/minute). Never subject a "cold" fan to a "hot" gas stream. When the fan is being taken out of operation the temperature of the gas must not decline at a rate greater than 15°F/minute (8°C/minute), and when the gas temperature has reached a level of 150°F (65°C) or less it is imperative that the fan be operated at this temperature for a period of time sufficient to allow the entire fan structure to reach an equilibrium temperature of 150°F (65°C). Only when the entire fan structure has reached an equilibrium temperature of 150°F (65°C) or less can the fan be shut off and removed from operation. Failure to follow these instructions may result in damage to the fan equipment. NEVER EXCEED THE MAXIMUM OPERATING TEMPERATURE OR SPEED FOR WHICH THE FAN WAS DESIGNED.
- (13) Connect the power source.
- (14) Fan impeller should always be stationary prior to startup. Startup while fan impeller is rotating backwards can cause damage.

- (15) Apply power to the driver momentarily (i.e. "bump") to check for proper rotation. Any dampers or other air control devices in the system should be at least partially closed during starting periods to reduce power requirements. Damper closure is particularly important in the case of a fan designed for high temperature operation being "run in" at a temperature less than design temperature.
- (16) Apply power to the driver and allow the fan to come up to design speed. Turn off. Look and listen for any unusual noise or mechanical action while the impeller is still spinning. If any are noticed, lock out all power sources, locate cause and correct.
- (17) Lock out all power sources and recheck tightness of all set screws, keys, foundation bolts and any other hardware. The initial start up will tend to relieve their tightness and they may require re-tightening.
- (18) Reconnect all power sources.
- (19) It is recommended that upon fan installation, the operating vibration levels be checked to ensure that the levels do not exceed the levels indicated on the inspection sheets shipped with the fan and/or the vibration levels set forth in the "Vibration" section of this manual.

Once it has been determined that the fan equipment is operating satisfactorily, it should be operated, if practical, for at least eight (8) continuous hours. Operation should be monitored at least once each hour during this period. Inspection should be made for any change of operation during this period. Some bearings will have to "run in" and will heat up during this period. The maximum bearing temperature should not exceed 200°F (93°C). It is normal for bearings lubricated with grease to purge a small amount of the grease through the bearing seals during run-in.

NOTE THAT ALL BOLTS, SETSCREWS AND V-BELTS SHOULD BE RE-TIGHTENED AFTER TWO (2) DAYS OF INITIAL OPERATION.

MAINTENANCE OF FAN EQUIPMENT

BEFORE STARTING MAINTENANCE WORK ON FAN EQUIPMENT LOCK MOTOR, LOCK DISCONNECT SWITCH IN THE OFF POSITION, DE-ENERGIZE AND DISCONNECT ALL POWER SOURCES TO THE MOTOR AND TO ACCESSORY DEVICES, AND SECURE FAN IMPELLER.

Bearings and Lubrication

Selection of the correct fan bearing lubricant and lubrication intervals depends on several factors. Extreme high or low temperatures and dirty or damp surroundings are all conditions that will create a requirement for more frequent lubrication or special lubricants. READ THE BEARING

MANUFACTURER'S INSTRUCTIONS TO DETERMINE THE TYPE AND FREQUENCY OF BEARING LUBRICATION REQUIRED.

THE MOTOR BEARINGS SHOULD BE LUBRICATED IN ACCORDANCE WITH MOTOR MANUFACTURER'S LUBRICATION INSTRUCTIONS AND RECOMMENDATIONS SHOULD BE FOLLOWED CLOSELY.

Bearing failure may be caused by failure to lubricate as often as required, use of an excessive quantity of lubricant or the use of incompatible lubricants. Excessive vibration, especially if the bearing is not rotating, will also cause bearings to fail. Bearings must also be protected from water and moisture to avoid internal corrosion.

Bearings are susceptible to damage from exposure to excess shaft heat transfer which may occur when a fan operating at a temperature greater than 200°F (93°C) is shut down without a sufficient period of gradual temperature reduction. See section (12) of "Operation of Fan Equipment" set forth on page 11 of this manual.

Bearing Replacement

Replacement of fan bearings should not be required for many years if cared for strictly in accordance with bearing manufacturer's instructions. The procedure used to replace fan bearings will vary depending on the type of fan and the type of bearing. It is important that the replacement of bearings be supervised or inspected by personnel experienced in such work and equipment. Trained personnel are available from Northern and arrangements for such supervision or inspection (at a fee) should be made through your local Northern representative or at Northern's head office.

Variable Inlet Vane

Once a year, the variable inlet vane coverplate should be removed and the moving parts re-packed with grease. The lubrication interval should be increased where moisture or particles are present in the airstream.

CAUTION: Where automatic control mechanisms are used to operate the variable inlet vane, care should be taken to correctly adjust control mechanism stroke limits as **OVERTRAVEL MAY DAMAGE THE VARIABLE INLET VANE OPERATING MECHANISM.**

Motors

DO NOT OPERATE THE MOTOR WITHOUT FIRST READING THE MOTOR MANUFACTURER'S INSTRUCTIONS. OPERATE THE MOTOR ONLY IN ACCORDANCE WITH THE INSTRUCTIONS.

The fundamental principle of electrical maintenance is to **KEEP THE MOTOR CLEAN AND DRY.** This requires periodic inspection of the motor. The frequency of the inspections depends upon the type of motor, the service and the motor manufacturer's instructions.

Periodic checks of voltage, frequency and current of a motor while in operation are recommended. Such checks ensure the correctness of frequency and voltage applied to the motor and yield an indication of the fan load. Comparison of this data with previous data will give an indication of the fan performance. Any serious deviations should be investigated and corrected.

Spare Parts

Spare parts may be ordered through your Northern sales office by providing the following information:

- (1) Part name (e.g. impeller, shaft, motor, bearing, etc).
- (2) Fan Serial Number from the nameplate.
- (3) If possible, the fan shaft diameter or bearing size together with the fan class specified on the nameplate.

DUE TO THE SMALL NUMBER OF PARTS REQUIRED, SPARE PARTS LISTS ARE NEITHER NECESSARY NOR AVAILABLE.

Vibration

A vibration analyzer must be used to accurately determine the level of fan vibration. Vibration readings should be taken by personnel experienced with vibration analysis and vibration analysis equipment. Trained personnel are available from Northern, and arrangements for vibration analysis (at a fee) may be made through your local Northern representative or at Northern's head office.

The fan should not be operated unless the **vibration velocity** of the fan is less than 0.20 inches per second.

If the vibration analyzer being used to measure vibration levels will provide only **vibration displacement** readings refer to Figure 5. Figure 5 is a graph used to determine whether the **vibration velocity** of a fan is acceptable or unacceptable if the vibration analyser is capable of measuring only the **vibration displacement**. To utilize Figure 5 it is necessary to identify the following:

- (1) the **vibration displacement** in mils (where 1 mil is equal to 1/1000th of an inch).
- (2) the **vibration frequency** in cycles per minute (generally taken as the fan speed in rpm).

Find the vibration displacement on the left vertical axis of Figure 5, and the vibration frequency on the horizontal axis. **DO NOT OPERATE THE FAN** if the point of intersection of these values lies in the region labelled "UNACCEPTABLE". All points in the region labelled "UNACCEPTABLE" are indicative of vibration velocities exceeding 0.20 inches per second and corrective action must be taken to reduce the vibration velocity below this value before the fan is returned to normal operation.

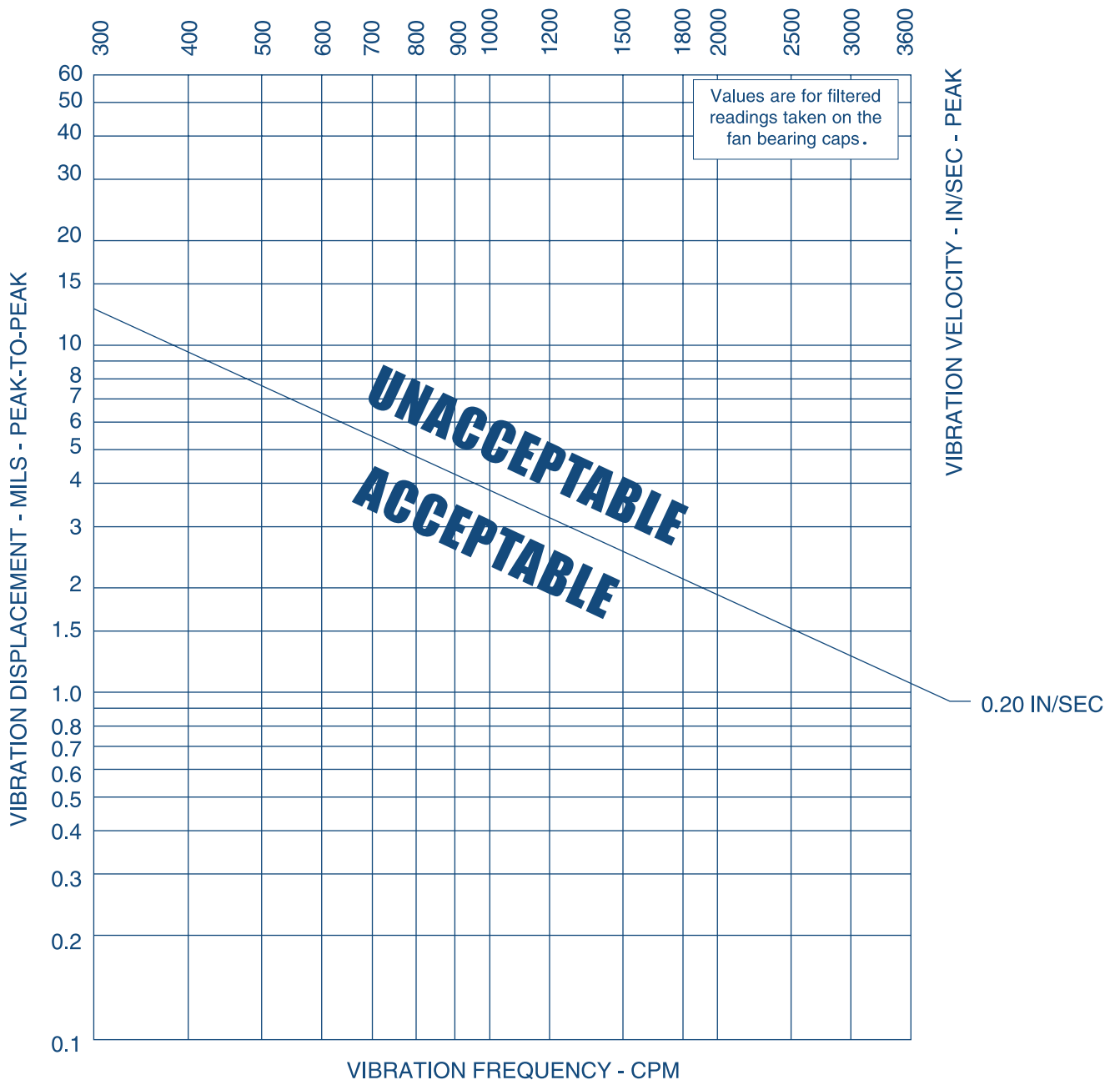

Fig. 5 Fan Vibration Severity Chart

FAN TROUBLE-SHOOTING CHART

PROBLEMS	PROBABLE CAUSES
INSUFFICIENT AIR FLOW	<ul style="list-style-type: none">. duct elbows near fan inlet or outlet. restricted fan inlet or outlet. impeller rotating in wrong direction. fan speed lower than design. system resistance higher than design. dampers shut. faulty ductwork. dirty or clogged filters and/or coils. inlet or outlet screens clogged
EXCESSIVE AIR FLOW	<ul style="list-style-type: none">. system resistance less than design. fan speed too high. filters not in place. registers or grilles not installed. improper damper adjustment
EXCESSIVE HORSEPOWER DRAW	<ul style="list-style-type: none">. fan speed higher than design. gas density higher than design. impeller rotating in wrong direction. static pressure less than anticipated. fan size or type not appropriate for application
EXCESSIVE VIBRATION	<ul style="list-style-type: none">. accumulated material on impeller. worn or corroded impeller. bent shaft. impeller or sheaves loose on shaft. motor out of balance. impeller out of balance. sheaves eccentric or out of balance. bearing or drive misalignment. mismatched belts. belts too loose or too tight. loose or worn bearings. loose bearing bolts. loose fan mounting bolts. weak or resonant foundation. foundation unlevel. structures not crossbraced. fan operating in unstable system condition
INOPERATIVE FAN	<ul style="list-style-type: none">. blown fuse. broken belts. loose sheave. motor too small. wrong voltage

OTHER INSTRUCTIONS and LITERATURE

FAN EQUIPMENT SERIAL No. _____ MAY CONTAIN COMPONENTS MANUFACTURED BY MANUFACTURERS OTHER THAN NORTHERN. SUCH MANUFACTURERS MAY HAVE FURNISHED INSTRUCTIONS AND/OR OTHER LITERATURE CONCERNING THEIR COMPONENT. A LIST OF SUCH INSTRUCTIONS AND/OR OTHER LITERATURE FORWARDED WITH FAN EQUIPMENT SERIAL No. _____ IS GIVEN BELOW.

(1) NORTHERN BEARING LUBRICATION INSTRUCTIONS:

- LUBRICATION INSTRUCTIONS FOR DOUBLE ROW SPHERICAL ROLLER BEARINGS 22500 SERIES SPLIT PILLOW BLOCK.
- LUBRICATION INSTRUCTIONS FOR SERIES 22400 SERIES DOUBLE ROW SPHERICAL ROLLER BEARINGS.
- LUBRICATION INSTRUCTIONS FOR 300 SERIES BALL BEARINGS.
- LUBRICATION INSTRUCTIONS FOR 200 SERIES BALL BEARINGS.

(2) BEARING MANUFACTURER'S INSTRUCTIONS:

YES NO

(3) MOTOR MANUFACTURER'S INSTRUCTIONS:

YES NO

(4) COUPLING INSTRUCTIONS:

NORTHERN COUPLING INSTRUCTIONS YES NO

COUPLING MANUFACTURER'S INSTRUCTIONS YES NO

(5) ACTUATOR/CONTROLLER MANUFACTURER'S INSTRUCTIONS:

YES NO

(6) OTHER LITERATURE/INSTRUCTIONS:



Northern Blower Inc.
901 Regent Avenue West
Winnipeg, Manitoba
Canada R2C 2Z8

☎ 204.222.4216

✉ 204.222.7601